

Name of research institute or organization:

École Polytechnique Fédérale de Lausanne (EPFL)

Title of project:

Study of the atmospheric aerosols, water vapor and temperature by LIDAR

Project leader and team:

Dr. Valentin Simeonov, project leader

Prof. Hubert van den Bergh, head of the Laboratory for Air and Soil Pollution

Dr. Marian Taslakov, Ioan Balin, Remo Nessler, Pablo Ristori, Todor Dinoev

Project description:

In 2004, the EPFL lidar group continued the operation of the multi-wavelength elastic-Raman scattering lidar in the framework of the European Aerosol Lidar Network EARLINET. The measurements were taken not on regular basis but only in favourable atmospheric conditions and during special events such as Saharan dust transport. Atmospheric temperature, aerosol extinction at two wavelengths (355 and 532nm), backscatter at three wavelengths (355nm, 532nm, and 1064nm), and water vapour mixing ratio were the measured parameters.

In 2004, the short-range receiver (based on a 20 cm Newtonian telescope) was upgraded with a depolarisation unit for the 355 nm channel. The unit was designed and built at EPFL and installed on the lidar receiver. It is based on a Wollaston prism and employs two Hamamtsu photomultipliers (Fig 1. left).

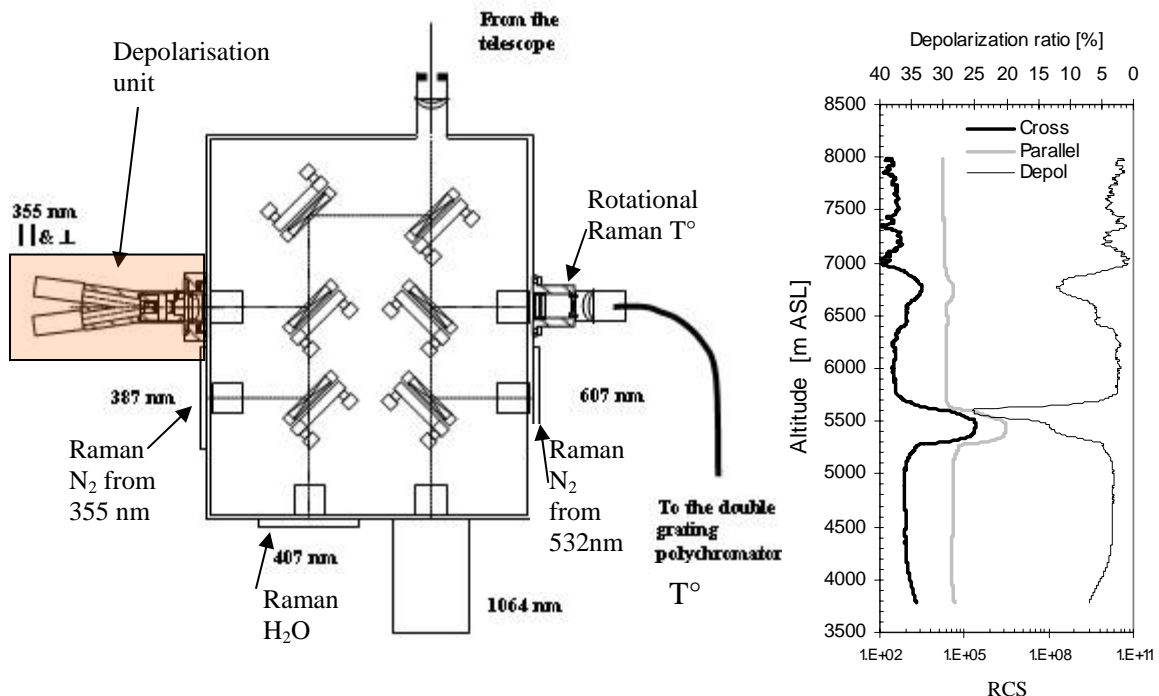

Fig. 1 *left* Short range receiver layout with the new depolarisation unit marked in red. *right* Parallel and cross (perpendicular) range corrected signals (RCS) together with the depolarisation ratio at 355 nm.

The depolarisation measurements are needed to distinguish spherical from non-spherical aerosol particles. The 355 nm depolarisation unit replaced the depolarisation

unit operated at 532 nm before May 2002 when the 532 nm signal started to be used for temperature measurements. The first measurements taken in March (Fig 1 right) demonstrate the presence of aerosol layer with relatively strong depolarisation (above 25 %) between 5300 and 5600m.

At present only the short-range receiver is in operation. The long-range receiver based on the 76 cm astronomical telescope will be added in the near future. The long-range receiver is already equipped with water vapour and multiple wavelength aerosol channels.

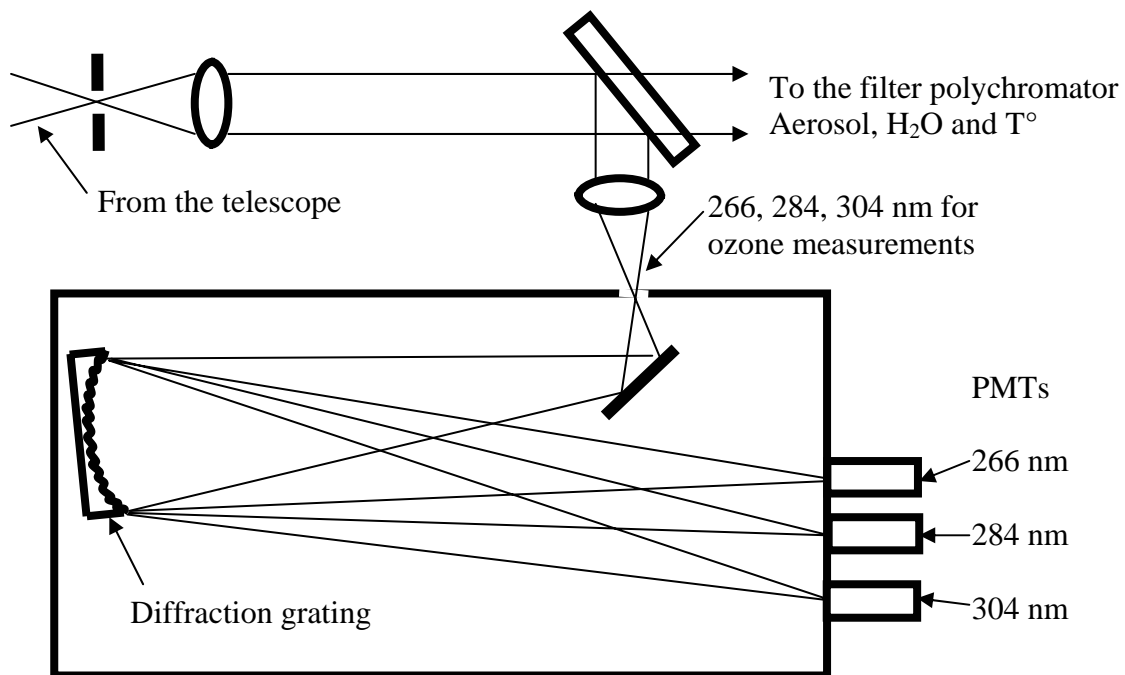

Fig. 2 Optical layout of the spectral separation unit for the ozone channel of the long-range receiver.

A spectral separation unit (Fig. 2) was designed for the new ozone channel of this receiver. The unit has a resolution of 1 nm/mm and is based on a UV enhanced flat field imaging grating (Jobin Yvon SA). The spectral separation unit will be installed together with the specially designed at EPFL six-wavelength transmitter and will allow ozone, water vapour, and multi-wavelength aerosol measurements to be taken with the lidar employing the 76 cm. astronomical telescope. A double-grating polychromator operated at 355 nm for temperature measurements with the long-range receiver is also under construction. The new transmitter together with the employment of the astronomical telescope and the new double-grating polychromator will enhance the lidar operational range for aerosol, temperature and water vapour measurements.

Key words:

Multi-wavelength lidar, Raman lidar, pure rotational Raman scattering, aerosols, backscatter and extinction coefficients, troposphere, water-vapor mixing ratio, temperature, Jungfraujoch site, EPFL, ozone

Internet data bases:

<http://lpas.epfl.ch/lidar/research/LidarJungfrau/Jungfrau.html>

Collaborating partners/networks:

EARLINET -European Aerosol Research LIdar NETwork
Paul-Scherrer Institute
ISM: Payerne station
Institute of Atmospheric Optics-Tomsk, Russia

Scientific publications and public outreach 2004:

Refereed journal articles

I. Balin, I. Serikov, S. Bobrovnikov, V. Simeonov, B. Calpini, Y. Arshinov, and H. Van den Bergh, "Simultaneous measurement of atmospheric temperature, humidity, and aerosol extinction and backscatter coefficients by a combined vibrational - pure-rotational Raman lidar", *Applied physics B*, **79**, pp. 775-782, (2004).

M. Taslakov, V. Simeonov, and H. van den Bergh, "Ozone detection by Quantum Cascade Laser Single-pulse spectroscopy", submitted to *Applied Physics B*.

M. Taslakov, V. Simeonov, and H. van den Bergh, "Quantum cascade laser based system for line-of-sight data transmission in the mid IR", to be published in "Laser physics and applications", SPIE vol. 5930, in print.

M. Taslakov, V. Simeonov, and H. van den Bergh, "Open path trace gas measurements using pulse quantum cascade laser", to be published in "Laser physics and applications", SPIE vol. 5930, in print.

Book sections

B. Calpini, V. Simeonov, Trace Gas species detection in the lower atmosphere by lidar in Takashi Fujii and Tetsuo Fukuchi (*eds.*) *Laser Remote Sensing*,: Dekker/-CRC Press, in press.

Conference papers

I. Balin, M. Parlange, B. Calpini, V. Simeonov, and H. van den Bergh, "Elevated atmospheric boundary layer over the Swiss Alps during the August 2003 heat wave", in the proceedings of the 22nd International Laser Radar Conference, Matera Italy 8-12 July 2004, pp 781-784.

I. Balin, V. Simeonov, I. Serikov, S. Bobrovnikov, B. Calpini, Y. Arshinov, and H. van den Bergh, "Simultaneous measurement of temperature, water vapor, aerosol extinction and backscatter by Raman lidar", in the proceedings of the 22nd International Laser Radar Conference, Matera Italy 8-12 July 2004, pp.139-142, pp. 139-142.

A. Papayannis et al, "Saharan dust outbreaks towards Europe: 3 years of systematic observations by the European lidar network in the frame of the EARLINET project (2000-2003)", in the proceedings of the 22nd International Laser Radar Conference, Matera Italy 8-12 July 2004, pp. 845-848.

V. Simeonov, P. Ristori, I. Balin, B. Calpini, H. van den Bergh, "A New DIAL Based on a N₂ Raman Converter for Ozone Monitoring; Design and Application during the ESCOMPTE Campaign", in the proceedings of the XX Quadrennial Ozone Symposium, Kos Greece, 1-8 June, 2004, V.1, pp. 109-110.

M. Taslakov, V. Simeonov, and H. van den Bergh, "Ozone detection by Quantum Cascade Laser Single-pulse spectroscopy", in the proceedings of the XX Quadrennial Ozone Symposium, Kos Greece, 1-8 June 2004, V. 1 pp. 603-604.

M.A. Taslakov, V.B. Simeonov, H. van den Bergh ;"Ozone detection by quantum cascade laser", 8-th International Global Atmospheric Chemistry Conference 4-9 September 2004 Christchurch New Zealand.

Theses

Ioan Balin, Monitoring of atmospheric water vapor, temperature, and aerosol by a multi-wavelength elastic-Raman lidar Data books and reports, PhD Thesis No 2975 EPFL.

Remo Nessler, Dry and Ambient Aerosol Properties at the Jungfraujoeh, PhD Thesis No 3051 EPFL.

Address:

EPFL ENAC LPAS
CH 1015 Lausanne

Contacts:

Valentin Simeonov
Tel.: +41 21 693 61 85
Fax: +41 21 693 36 26
e-mail: valentin.simeonov@epfl.ch